

LIE-312-#

high performance pyroelectric detector

Description:

single channel; TO39 housing; medium chip size; JFET; voltage mode; long time constant, metal black coating



HOUSING:

PIN ASSIGNMENT:

TO39 3Pin
Bottom view

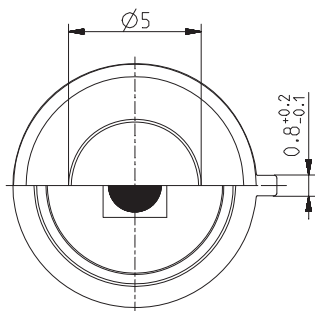
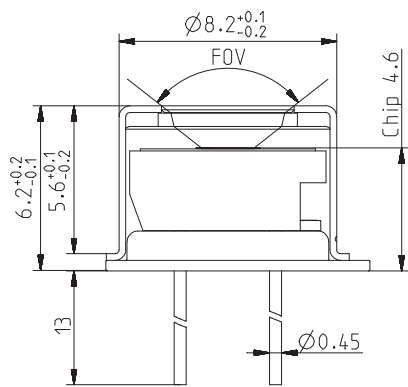
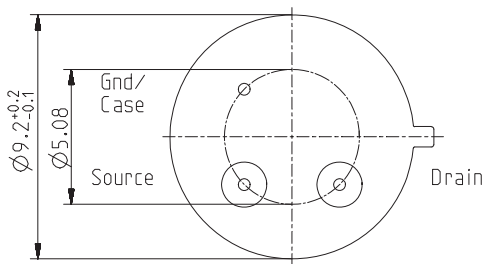

Top view

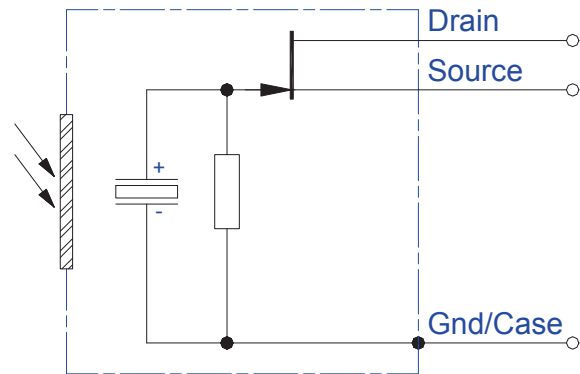

FREQUENCY RESPONSE:

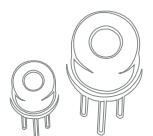
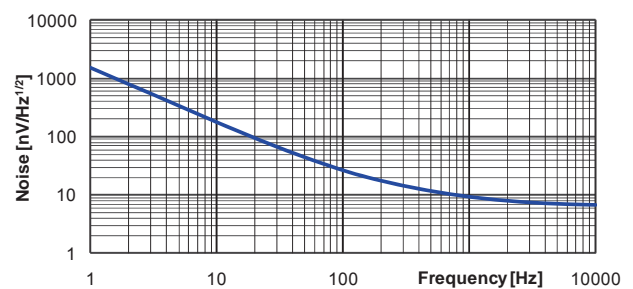
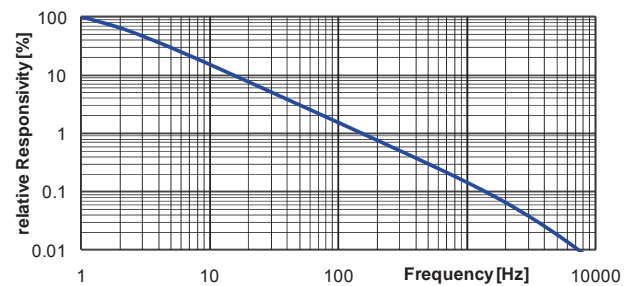

LIE-312-#

high performance pyroelectric detector

TEST CIRCUIT:

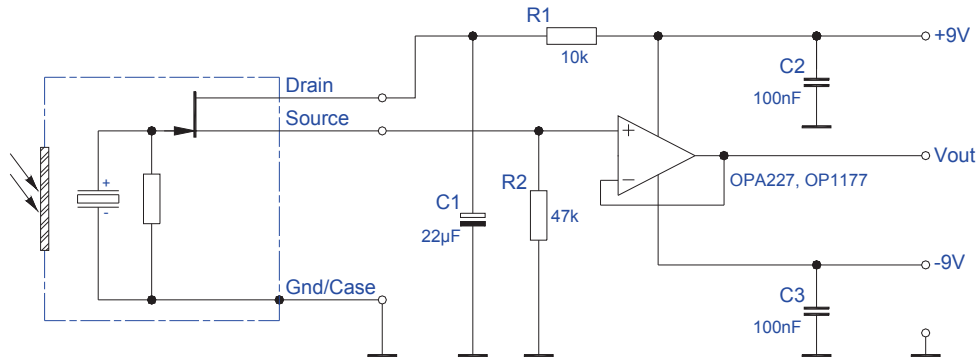

PARAMETERS:

Aperture size	nom	ø5.0 mm
Element size / type	nom	ø2.0 mm lithium-tantalate with metal black layer
Thermal time constant	typ	200 ms
Electrical time constant	typ	5 s
Polarity	nom	positive signal by positive IR flux change
Voltage responsivity (rms) {500 K, 10 Hz, 25 °C, without filter/window}	min	500 V/W
Voltage responsivity (rms) {500 K, 100 Hz, 25 °C, without filter/window}	min	50 V/W
Noise density (rms) {10 Hz, BW 1 Hz, 25 °C}	max	180 nV/(sqrt[Hz])
Noise density (rms) {100 Hz, BW 1 Hz, 25 °C}	max	35 nV/(sqrt[Hz])
Detectivity {500 K, 10 Hz, 1 Hz, 25 °C, without filter/window}	typ	8.0E+08 cm(sqrt[Hz])/W
Detectivity {500 K, 100 Hz, 1 Hz, 25 °C, without filter/window}	typ	4.0E+08 cm(sqrt[Hz])/W
Detectivity {500 K, 1 kHz, 1 Hz, 25 °C, without filter/window}	typ	1.6E+08 cm(sqrt[Hz])/W
Offset voltage {opt. Drain current = 10 ... 100 µA}	nom	0.4 ... 1.5 V
Drain source voltage	max	18 V
Operating / Storage temperature	nom	-25 ... +60 °C
IR window		All InfraTec standard crystal windows (BaF2, CaF2, CsI, KBr, Sapphire) are available. Customized filters upon request.
Filter sizes	nom	rectangular filters: (5.25 x 5.25) mm +0/-0.05 mm circular filters: ø6.5 mm ±0.1 mm standard thickness: 0.50 mm +0.2/-0.1 mm max thickness: 0.85 mm
Field of View	min	CaF2 or BaF2; 0.4 mm thick: 90°

InfraTec reserves the right to change these specifications at any time without notification.

